

Model 10

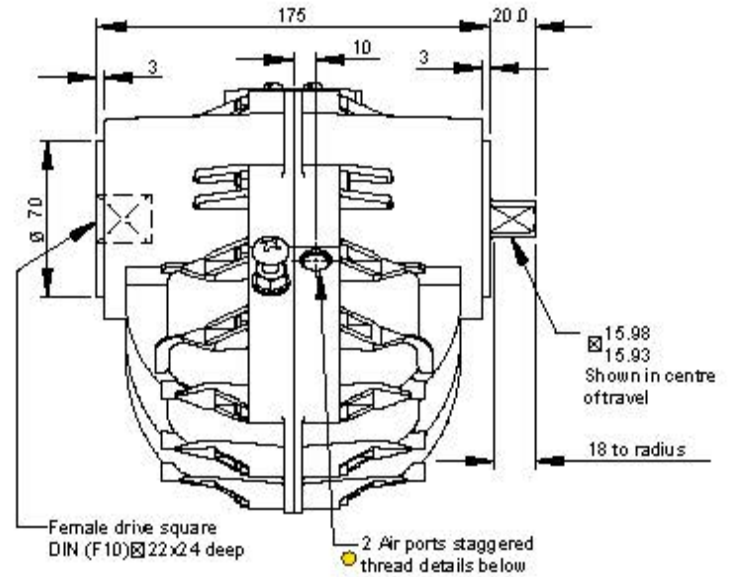

Visual Indicator Standard



Specification

Output Torque

3625 lbf ins/416 Nm
at 100 psi/7 bar

Angle of Travel (adjustable)

78° - 100°
(restricted travel versions available)

Displaced Volume

62.5 in³/1025 cm³

Finish

Epoxy stove enamel

Weight

12.3 lb/5.6 kg
(no coupling)

For further information see General Specification on page 50.

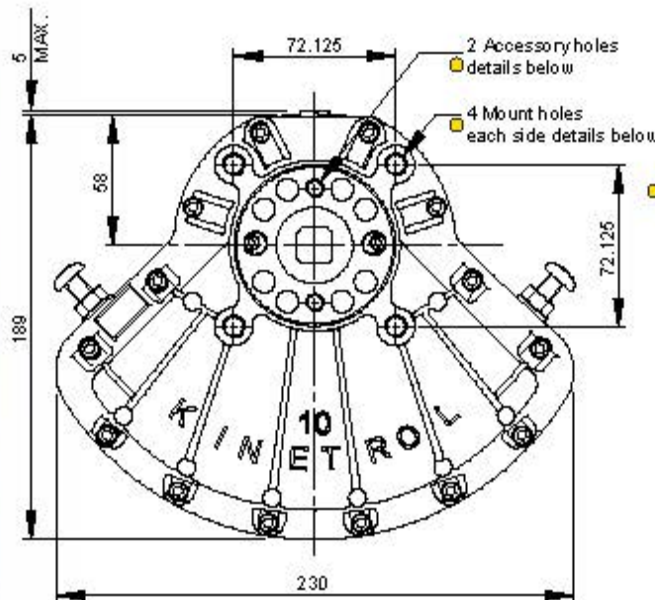

Model	Air Ports	Mount Holes & Accessory Mount Holes
103-100	G ¹ / ₄	4 x M10 x 16 deep on 102.0 PCD
107-100	1/4 NPT	2 x M8 x 16 deep on 50.8 PCD
		4 x 3/8 UNC x 0.63" deep on 4.02" PCD
		2 x 5/16 UNC -18 x 0.63" deep on 2.00" PCD

Female drive and mounting details to DIN 3337 and ISO 5211 as standard

Options

- Fail safe spring return units - clockwise or counter clockwise see pages 5-7
- Limit switch boxes for open/close indication - various switches for hazardous areas see pages 9-12
- Integral solenoid valve see page 20
- AP pneumatic positioner - full range of options see pages 17/18
- EL electropneumatic positioner - full range of options see pages 15/16
- P3 on/off positioner - full range of options including hazardous area see pages 21-23
- Clear Cone position monitor see page 20
- Geared manual override see page 46
- Code identification see page 62
- Torque outputs see pages 58-60
- See pages 49-52 for English dimensions and dimensions of spring options
- High temperature / Low temperature options see page 50

